

JOHN LOUIS HOME

Solid Wood Home Storage Solutions

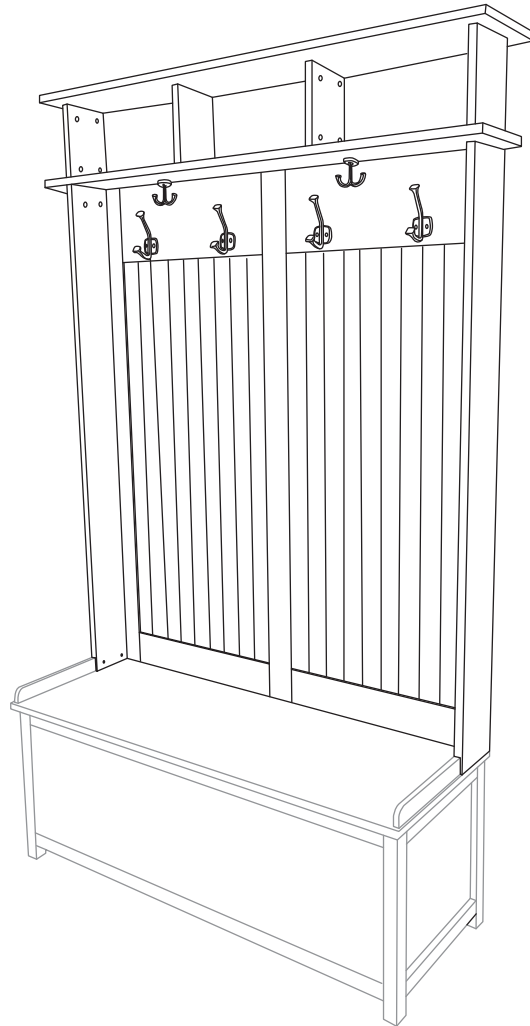

Installation Instructions



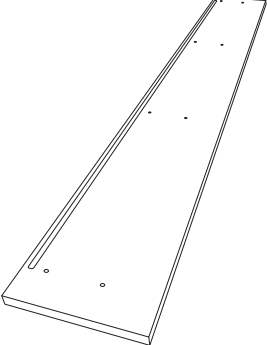
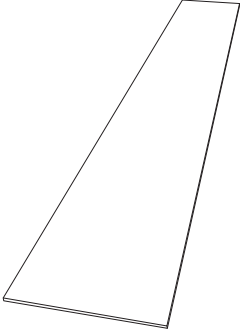
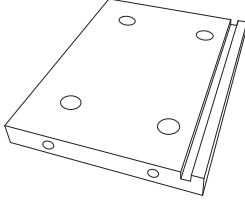
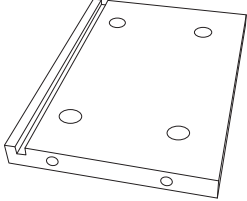
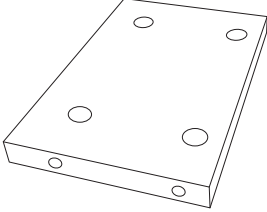
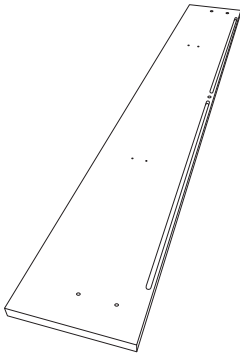
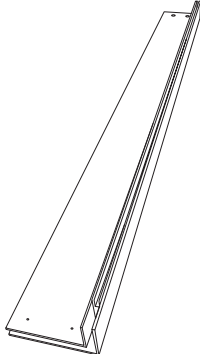
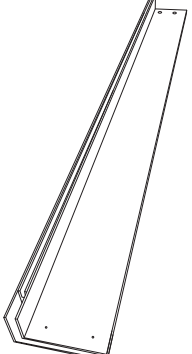
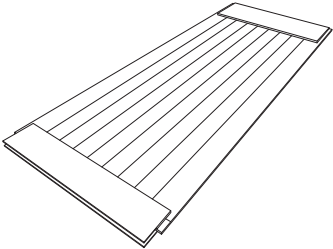
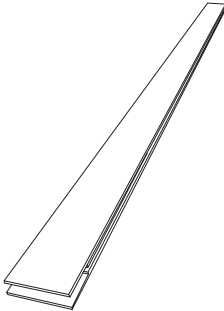
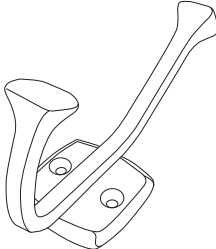
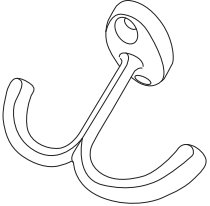

Hall Tree Bench Attachment

JLH-HT*

Parts List

			
A 1 Extension Top	B 1 Extension Back	C 1 Ext. Left Side	D 1 Ext. Right Side
			
E 2 Ext. Divider	F 1 Top	G 1 Left Corner	H 1 Right Corner
			
I 2 Back Panel	J 1 Panel Divider	K 4 Back Hook	L 2 Top Hook

Hardware List

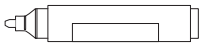
				
M 21 CAM Bolt	N 21 CAM Bolt	O 5 #6 3/4 screw	P 12 #8 3/4 screw	Q 1 Touch Up

Thank you for your purchase. For any product or installation questions, damages, replacement or missing parts please contact us at:

1.800.480.6985

service@johnlouishome.com

www.johnlouishome.com

The John Louis Home Hall Tree Bench Attachment can be used with or without the top storage cube extension. For use without the top extension **skip to Hall Tree Assembly Steps**

STORAGE CUBE TOP EXTENSION ASSEMBLY

Step 1

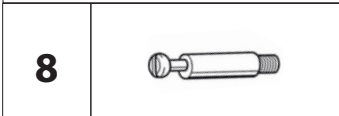
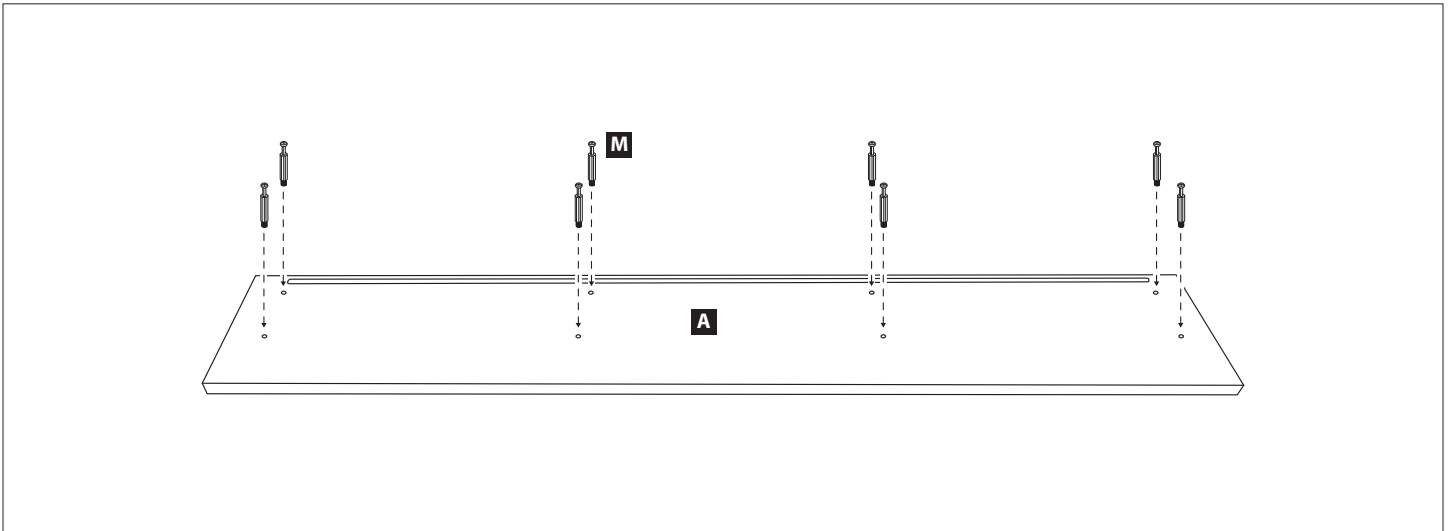

Step 2

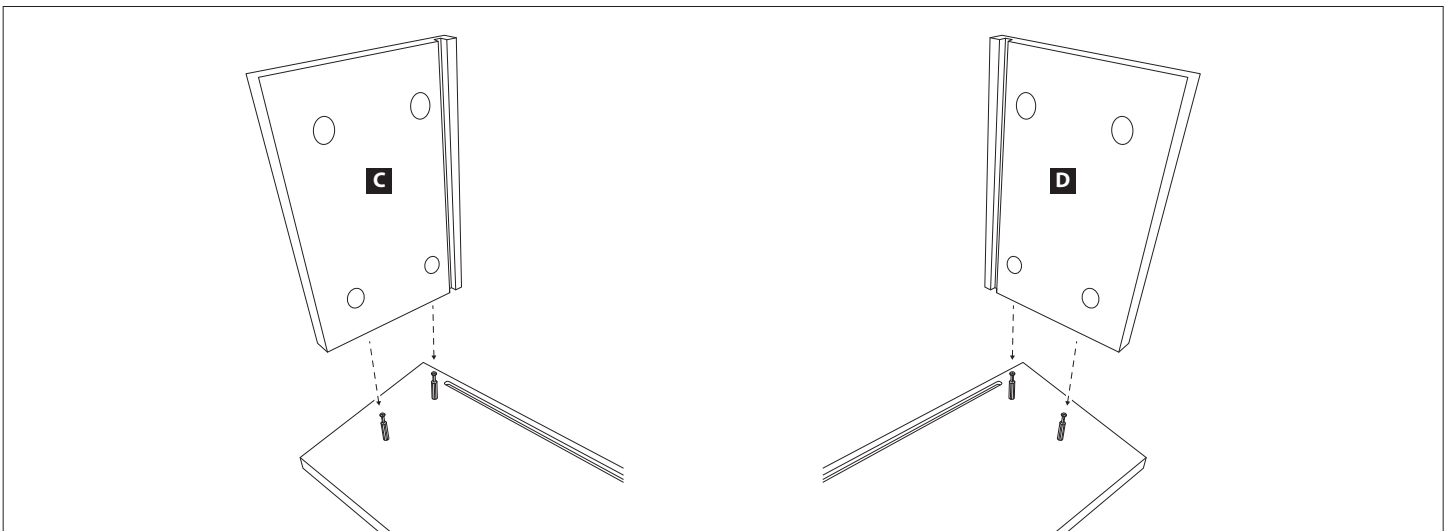

Step 3

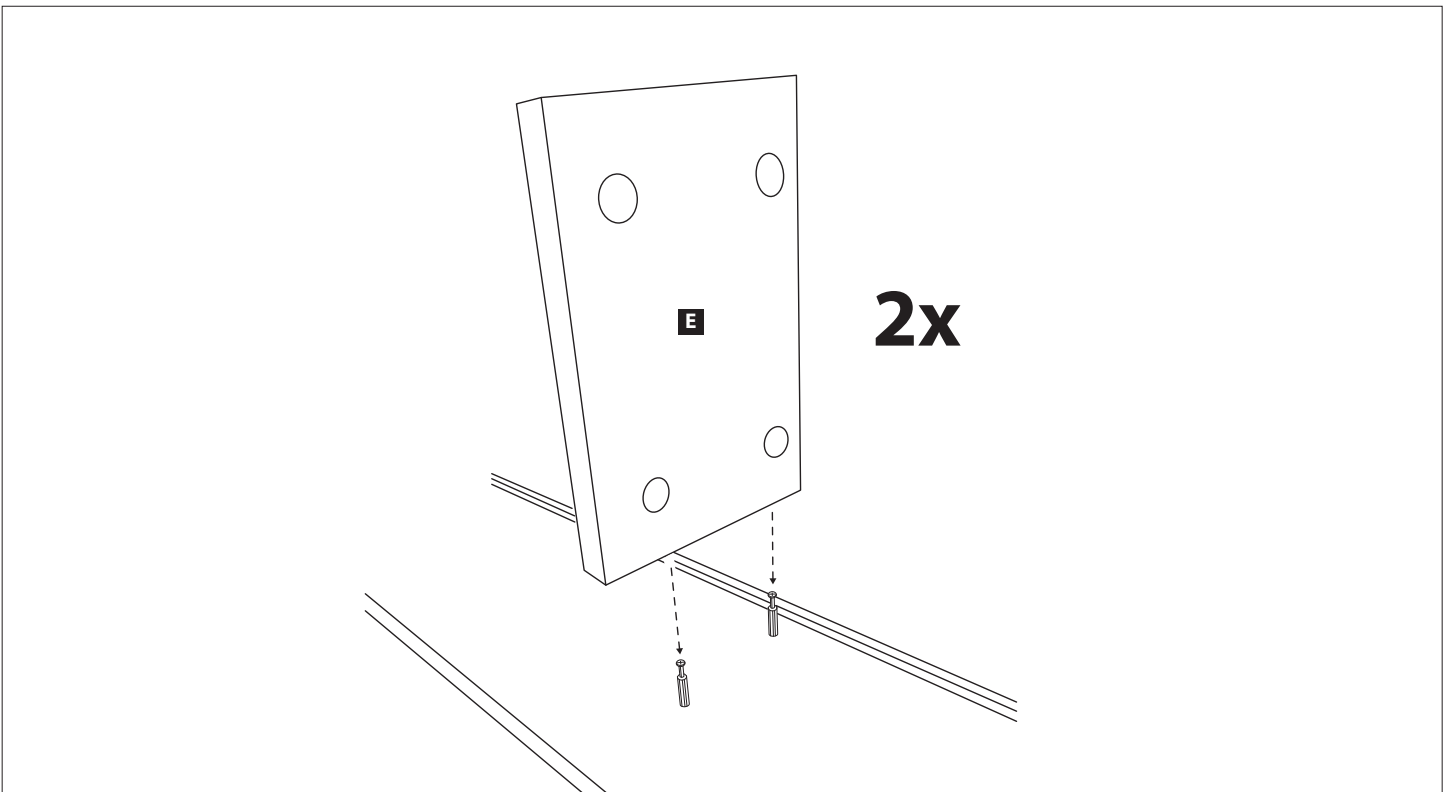

Step 4

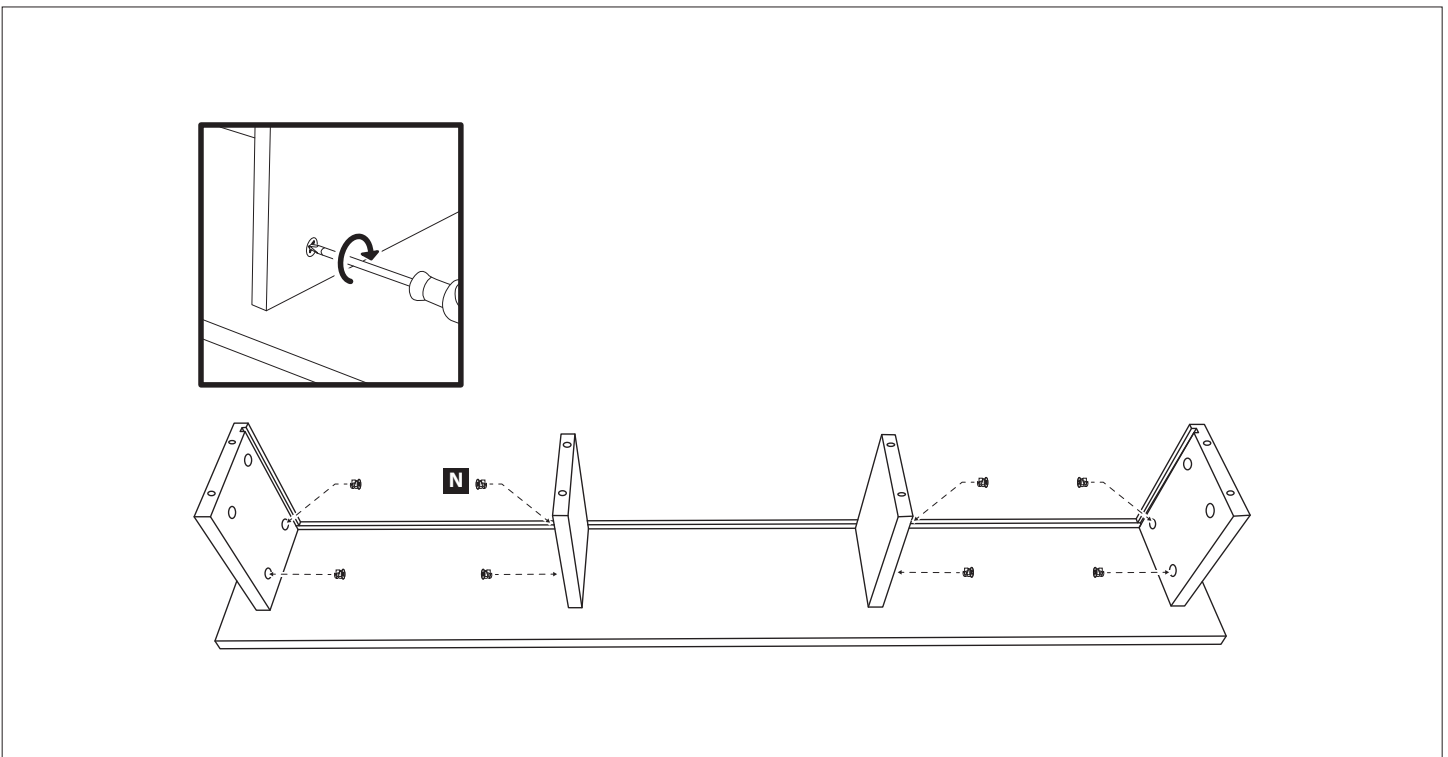

Step 5

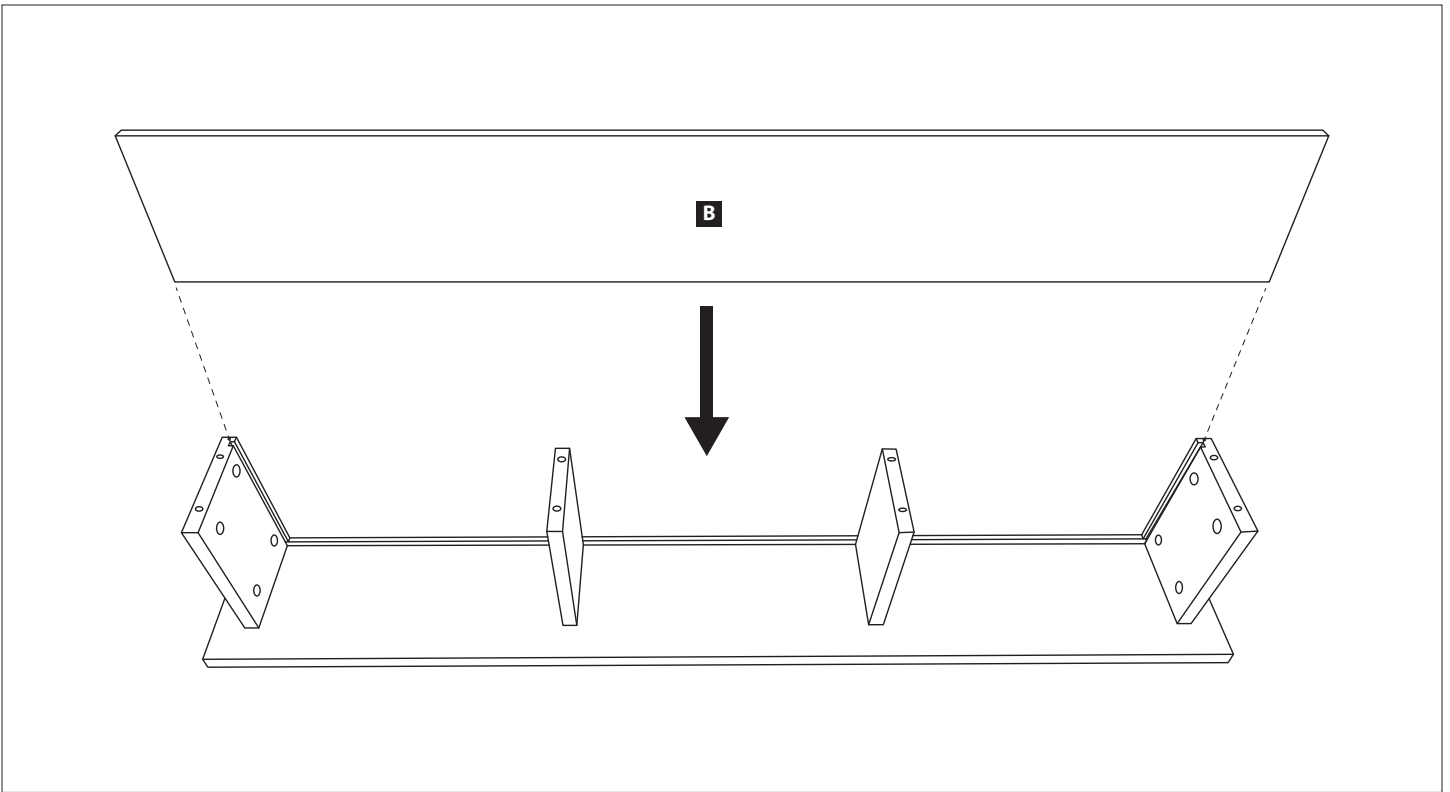

Step 6

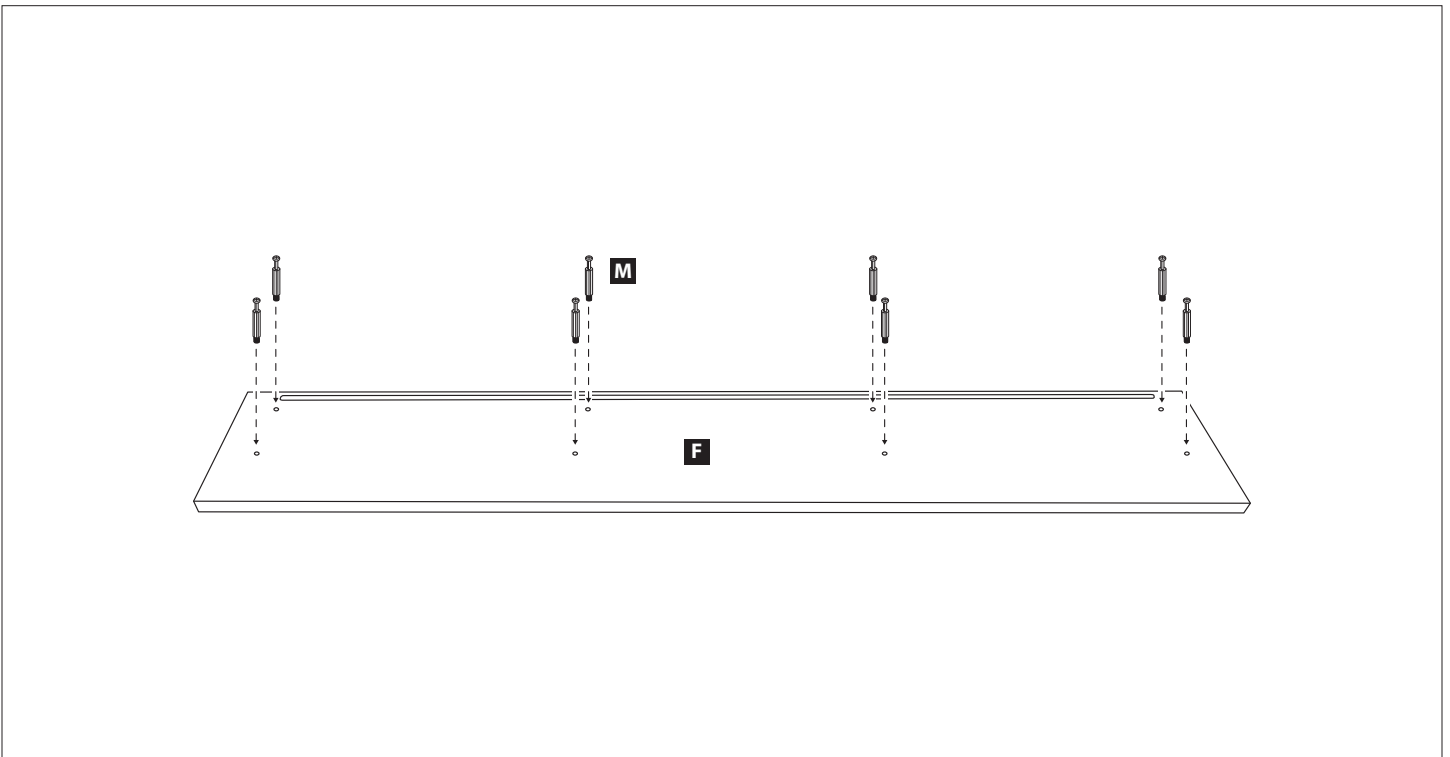

8

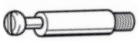

Step 7

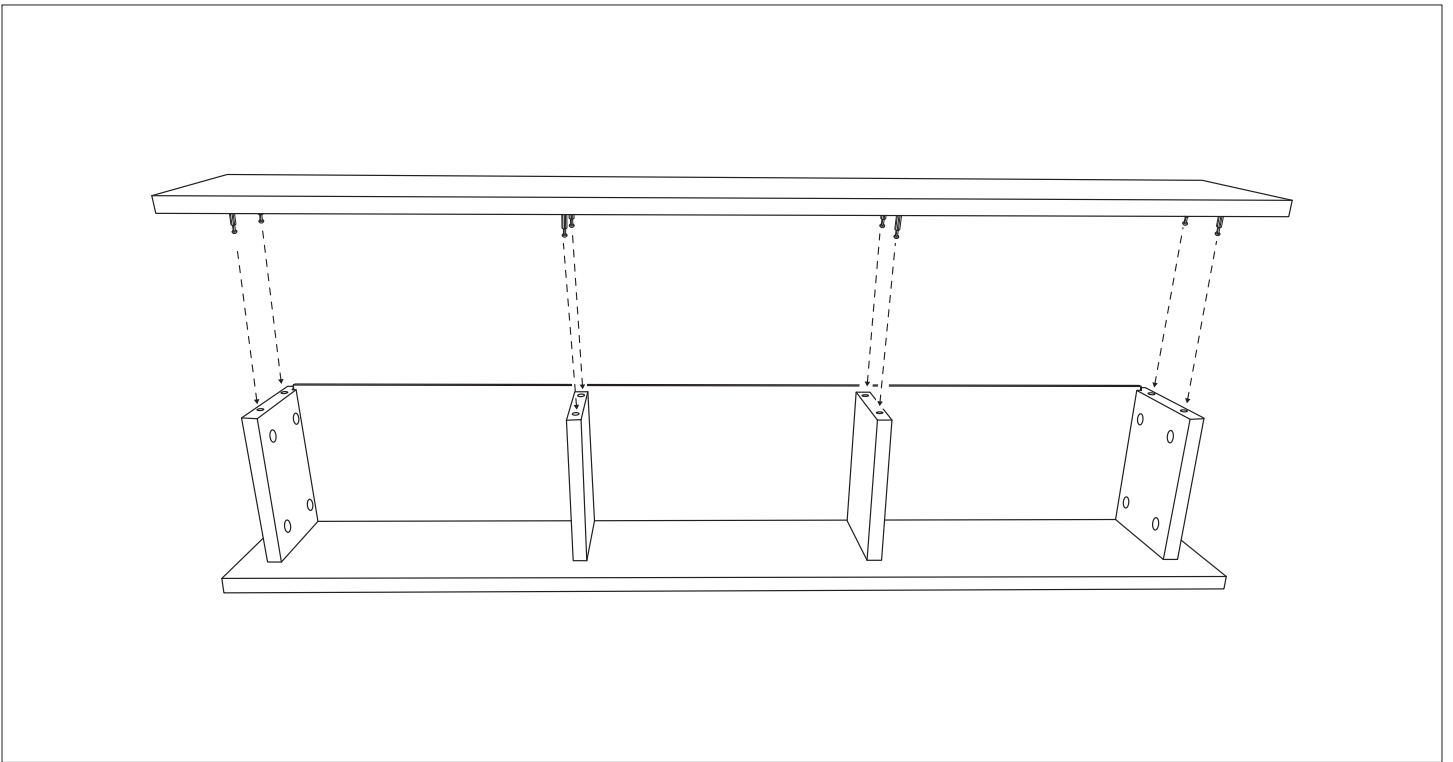

Step 8

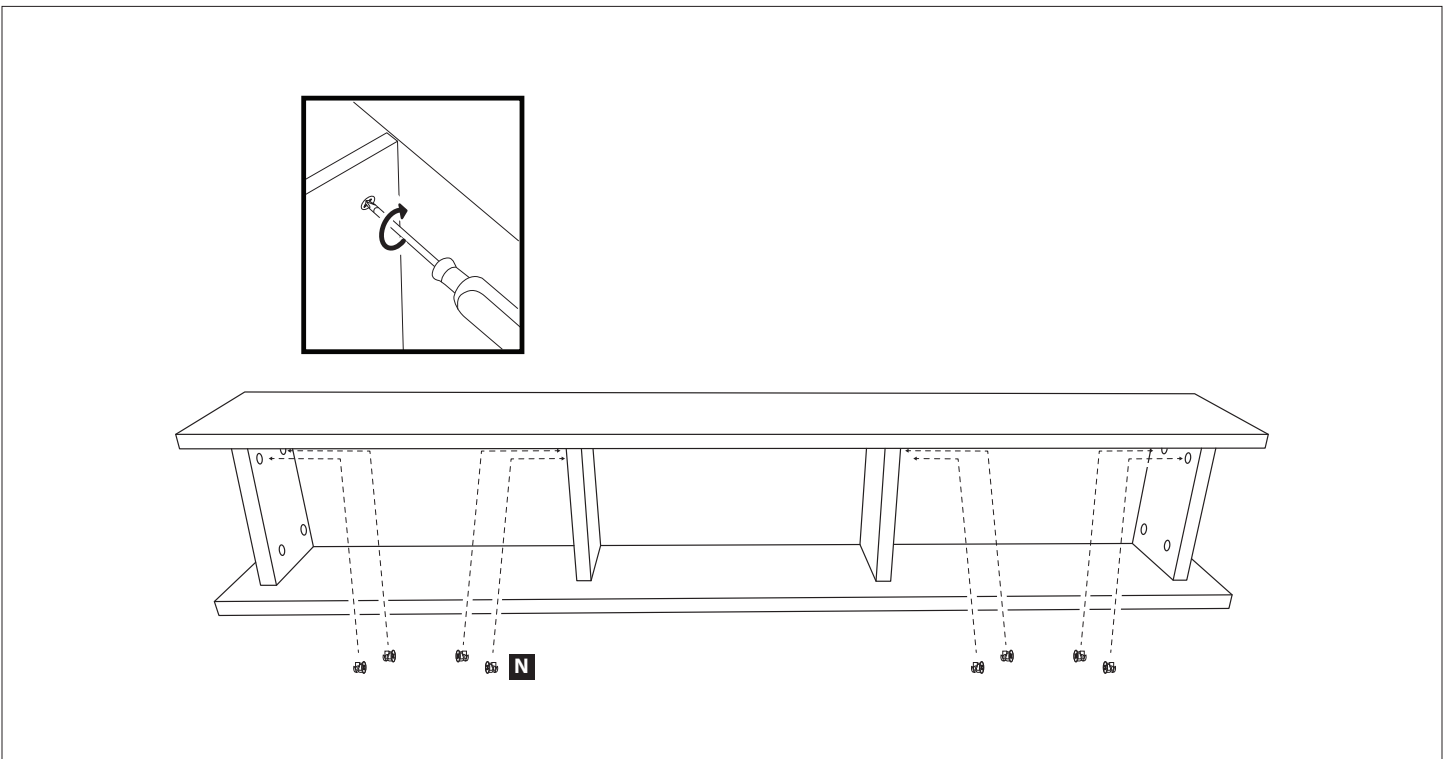

HALL TREE ASSEMBLY

Step 1

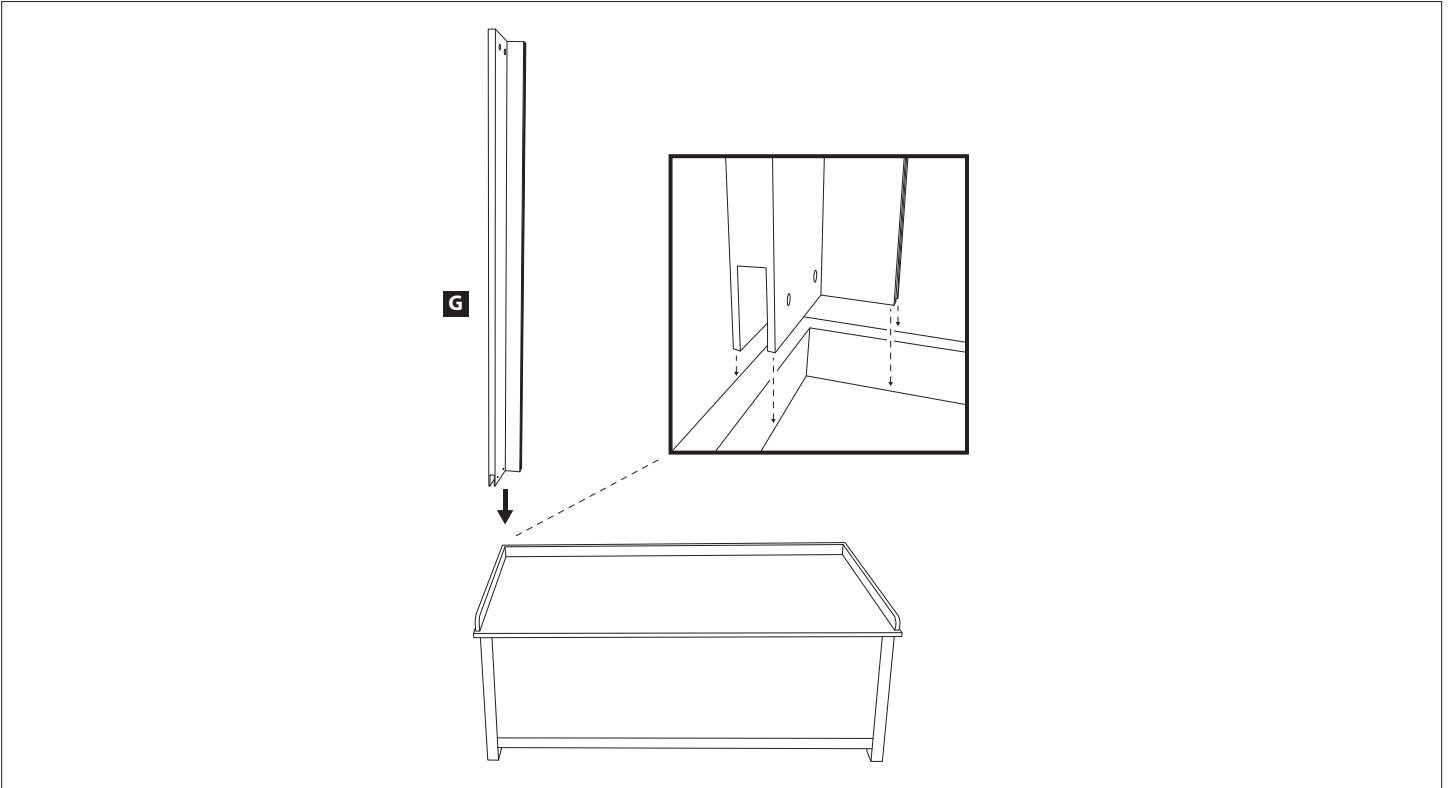

Step 2

Back Panel is reversible and may be used with either grooved or flat side facing front.

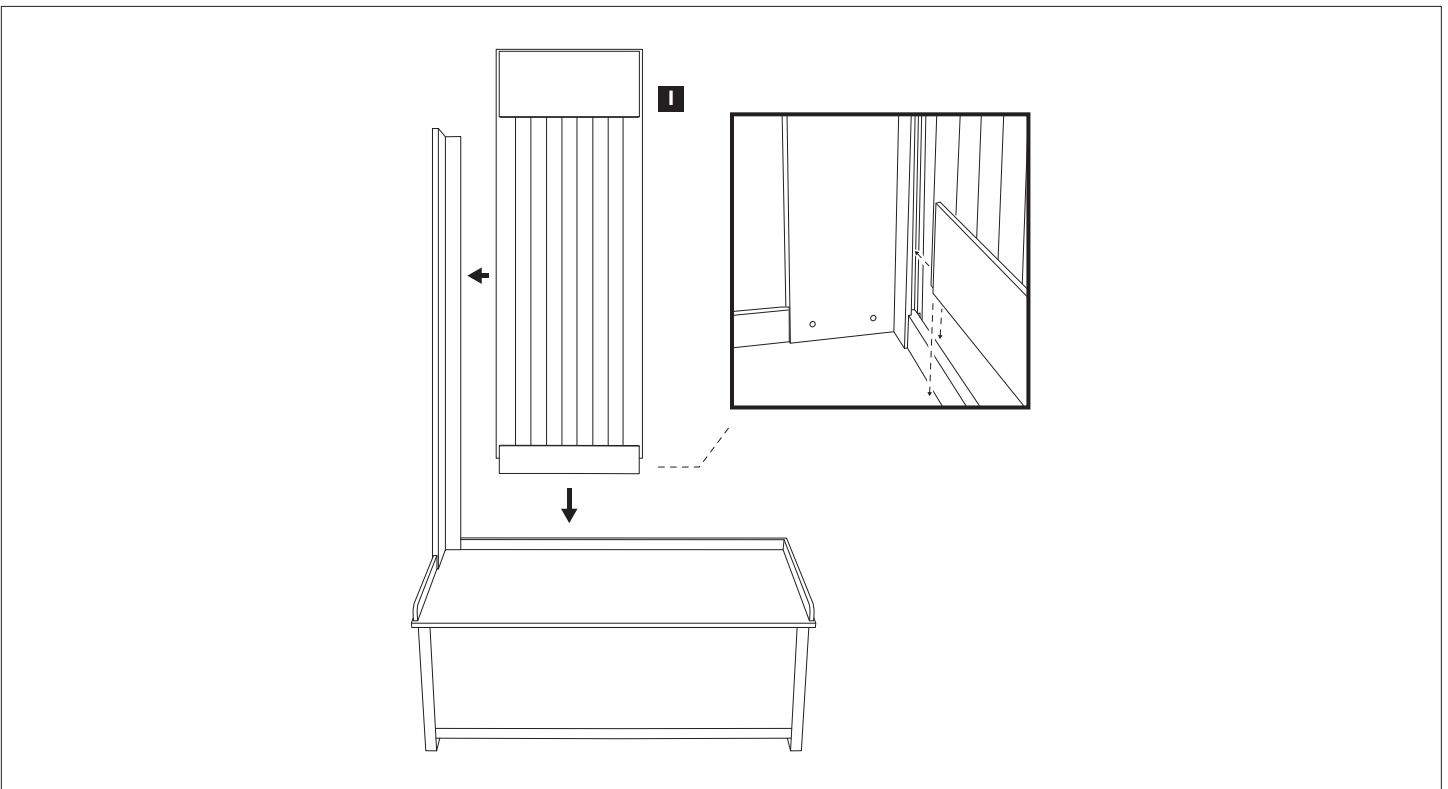

Step 3

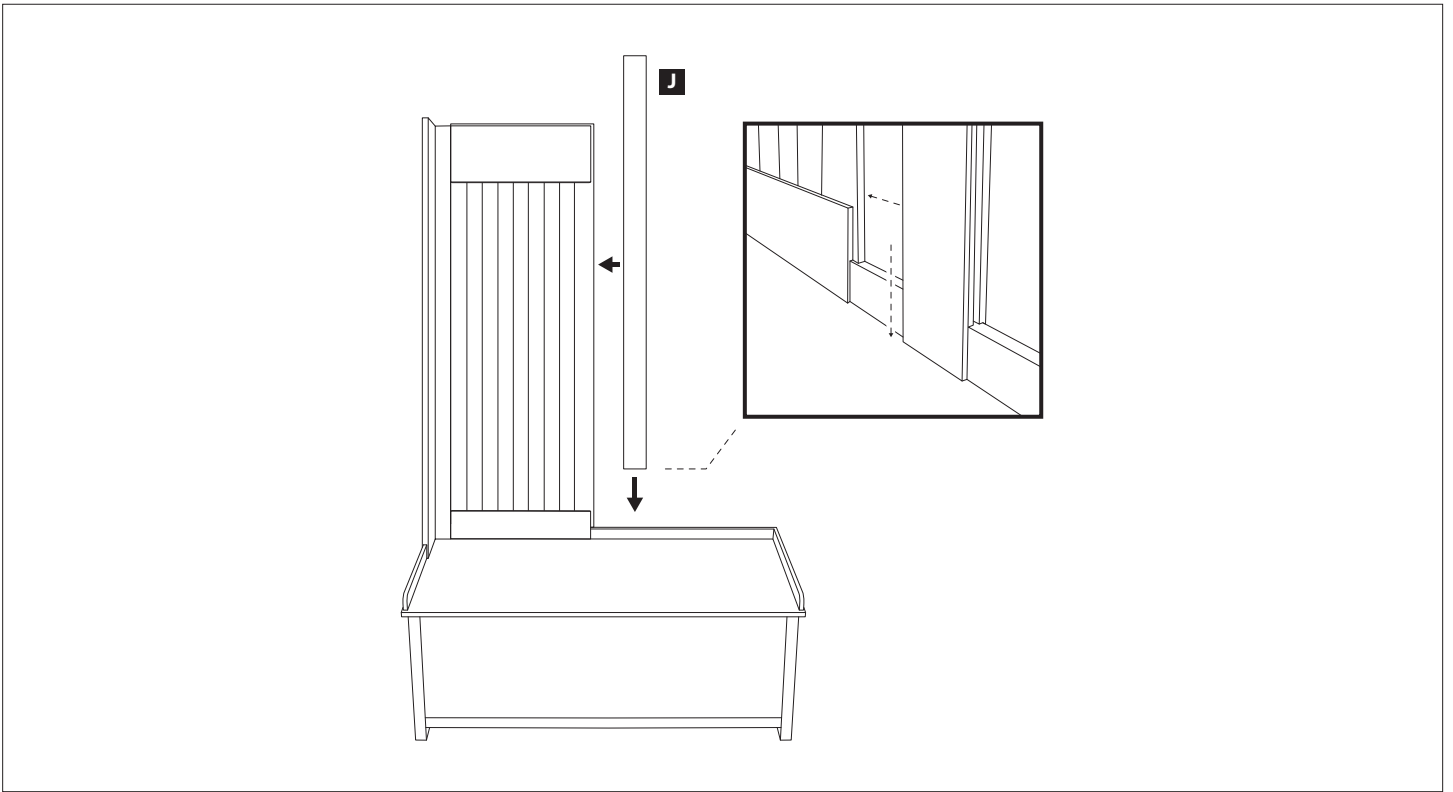

Step 4

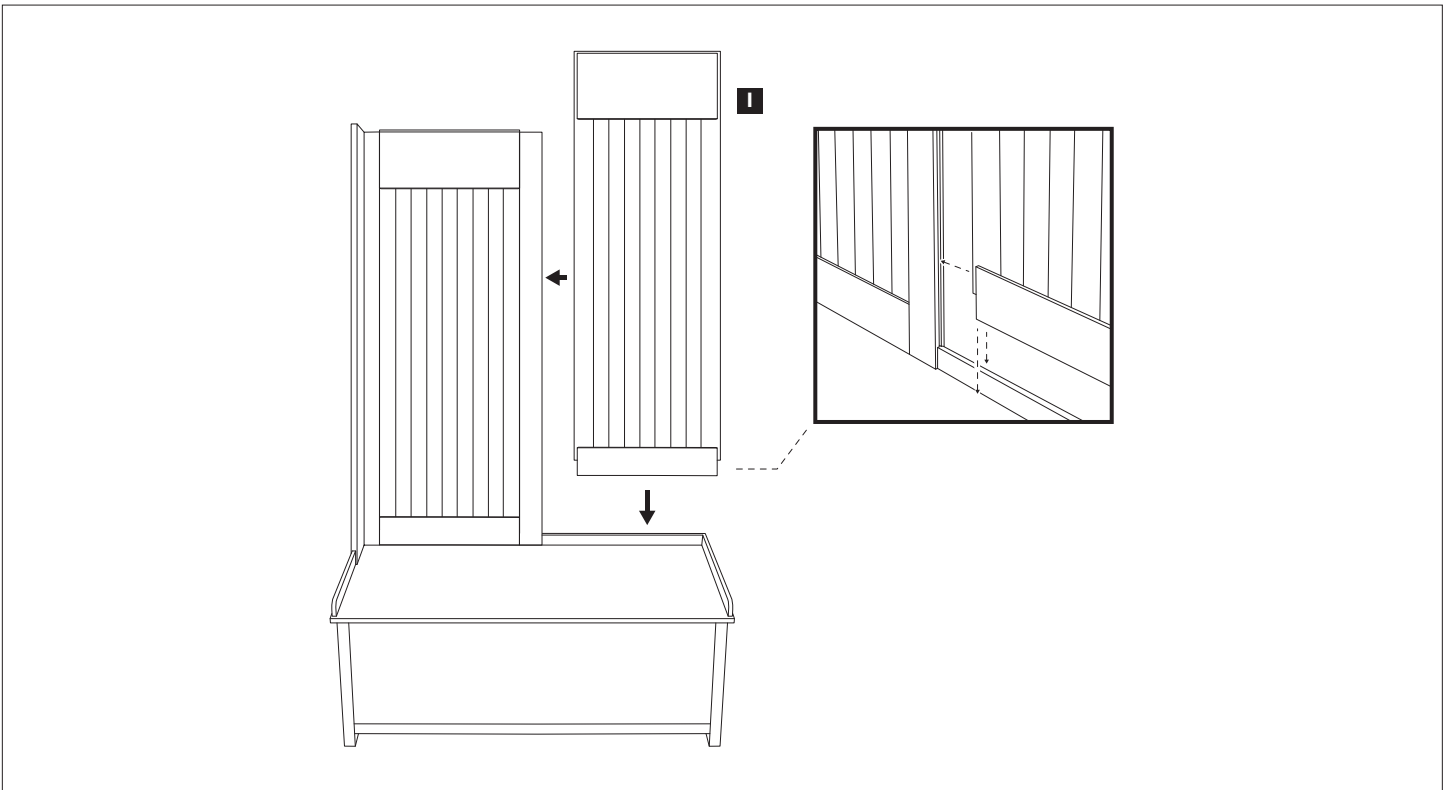

Step 5

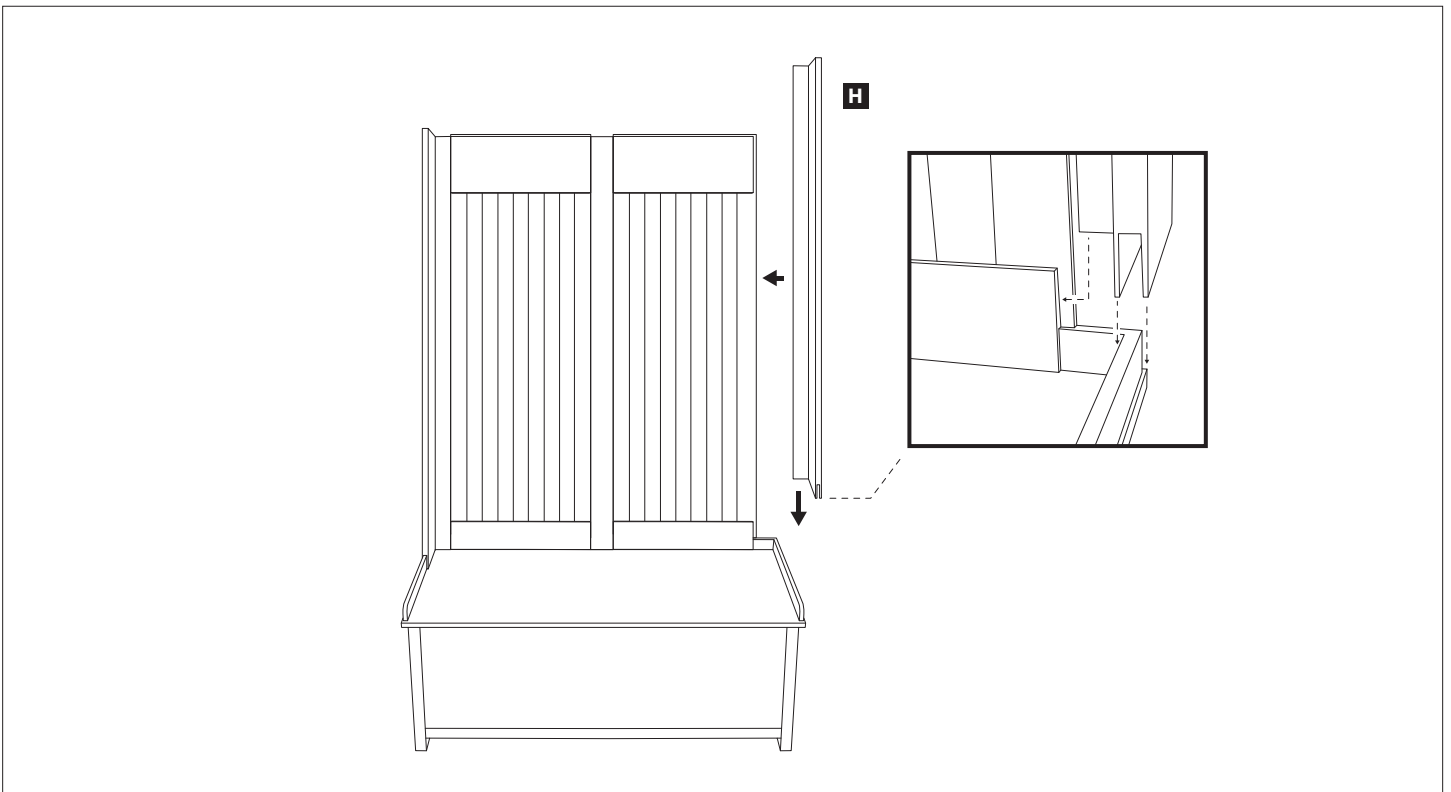

Step 6

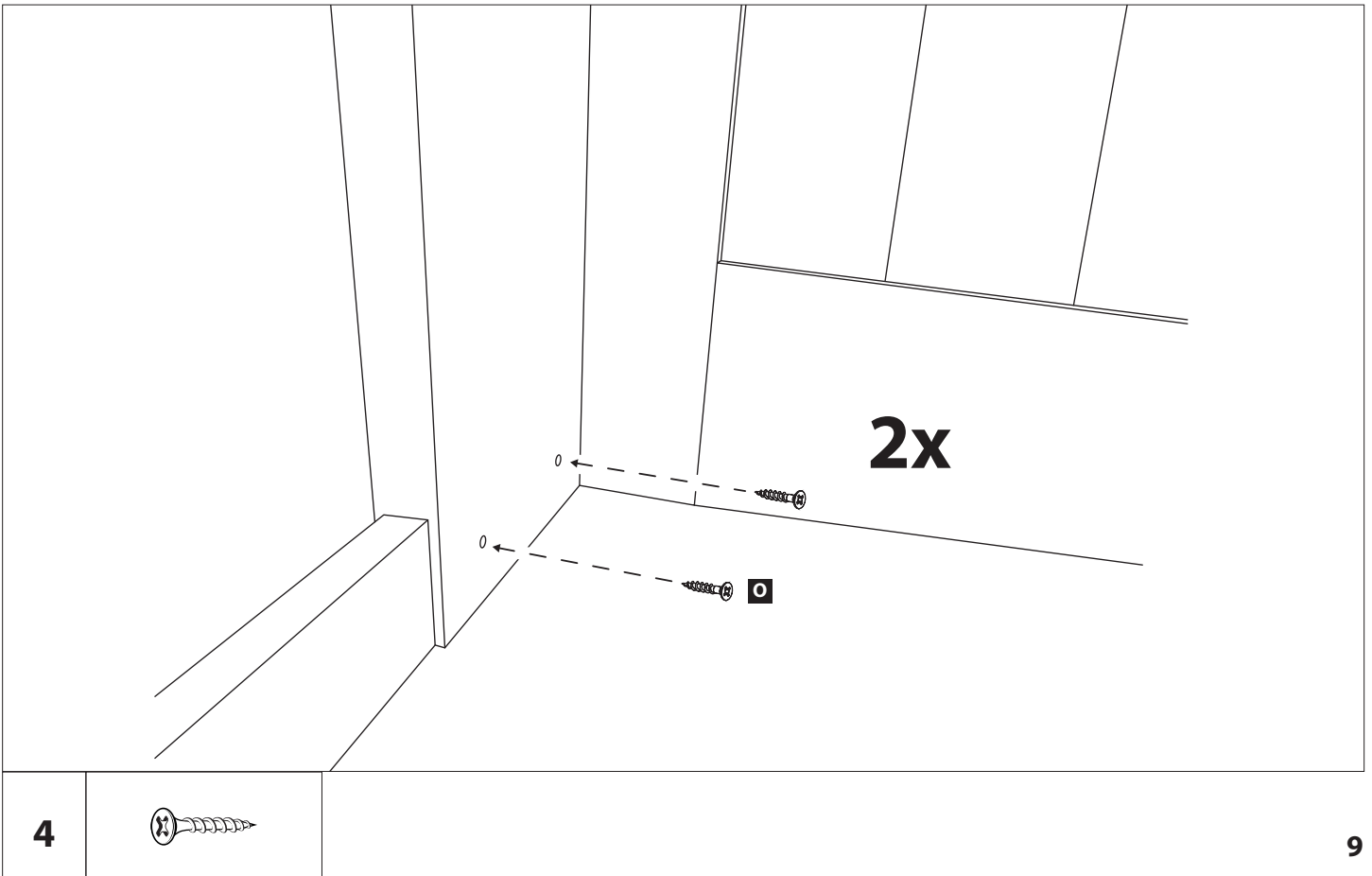

Step 7

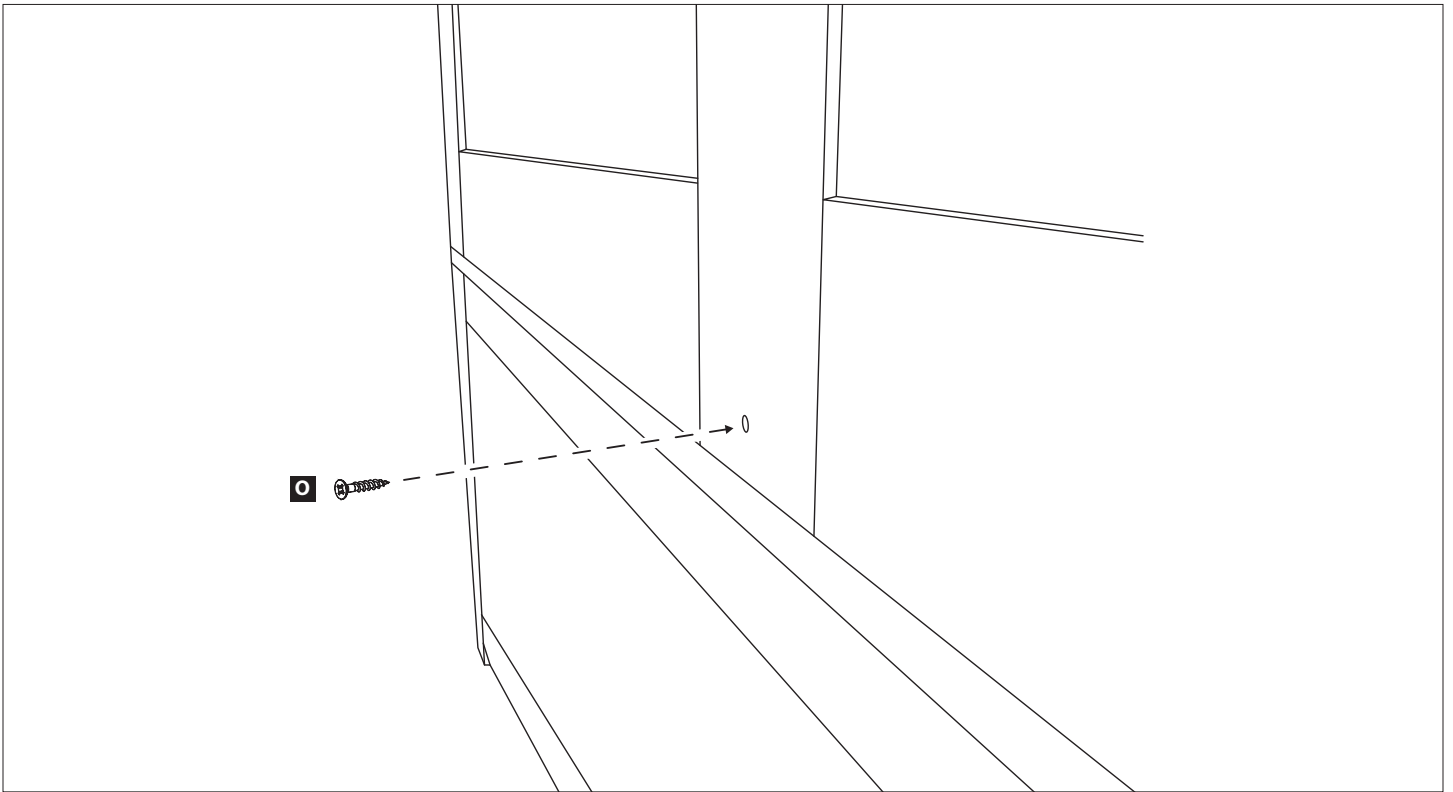

1



Step 8

Without Extension

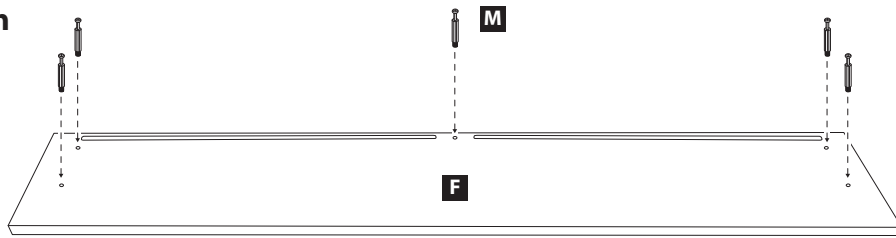

With Extension

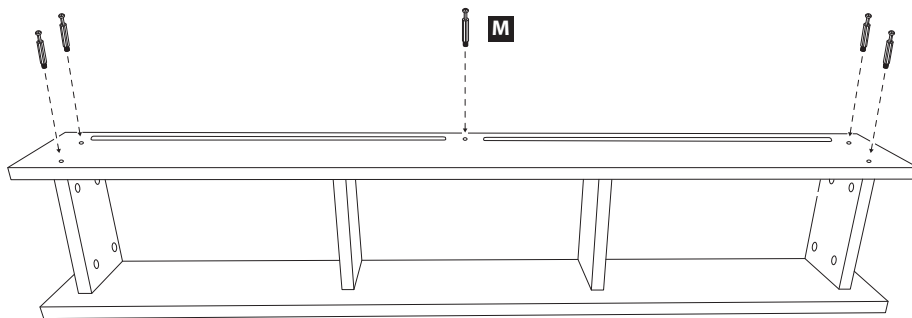

5



Step 9

Without Extension

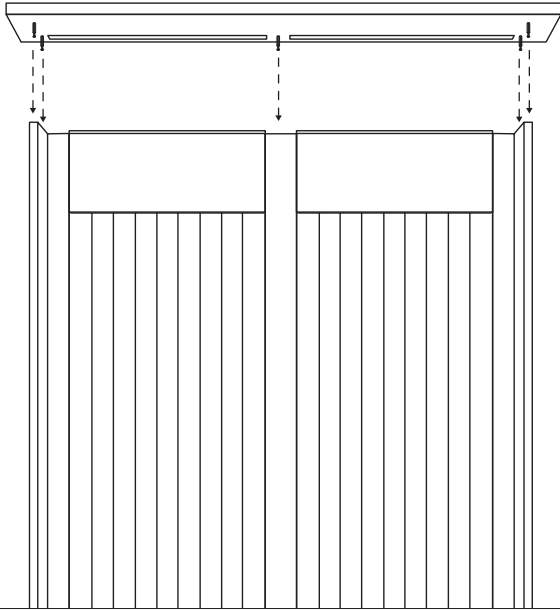

With Extension

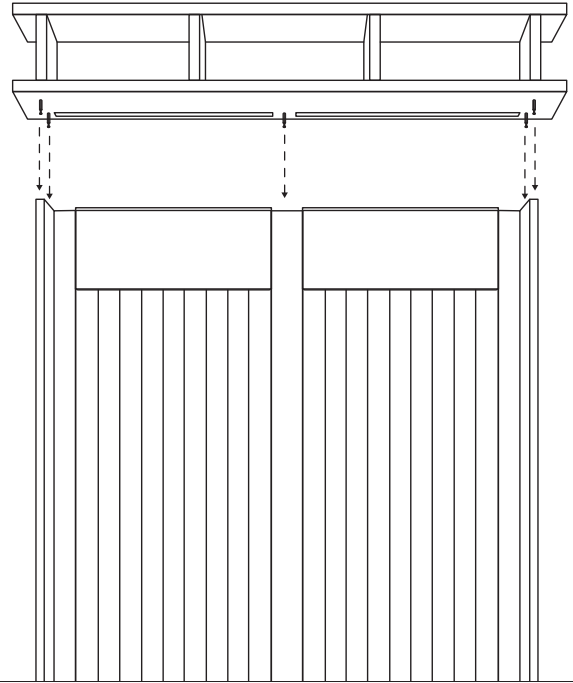

Step 10

Without Extension

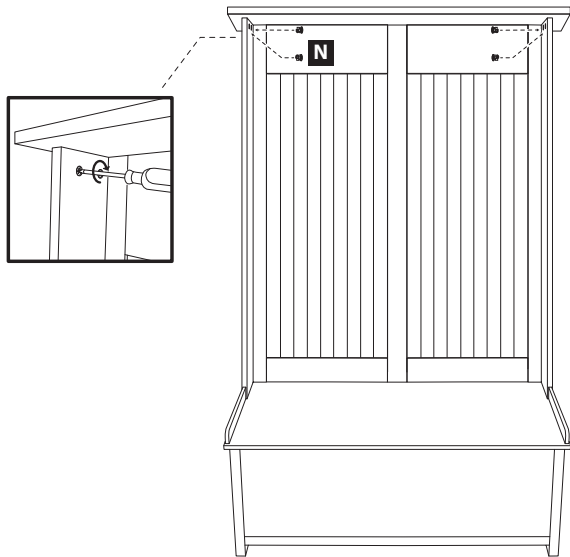

With Extension

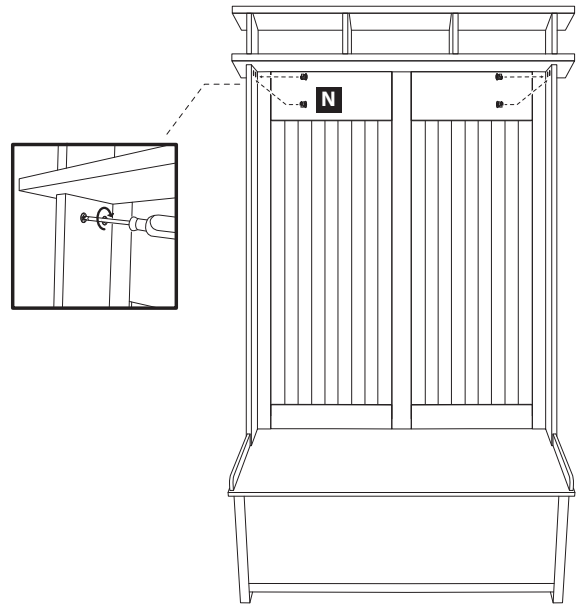

Step 11

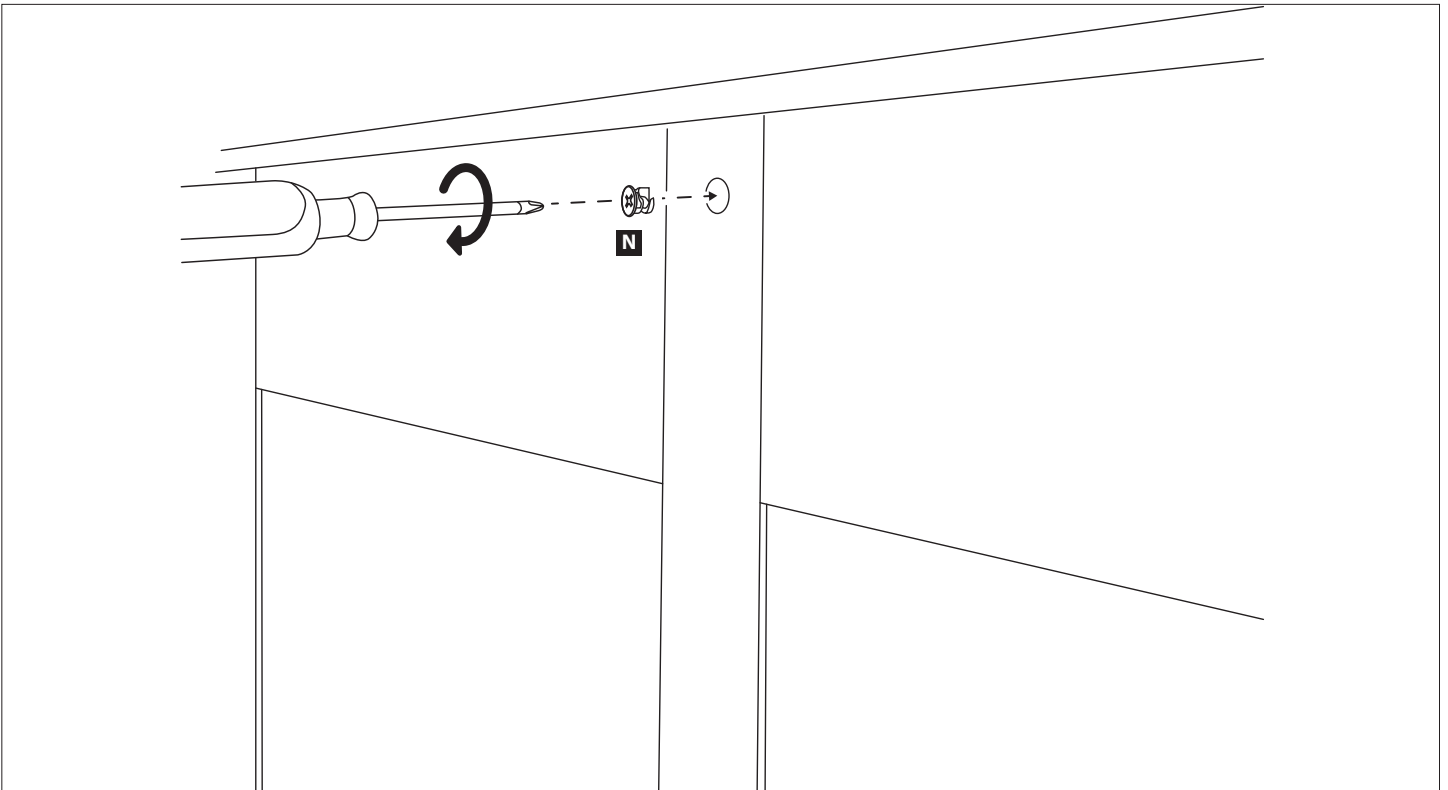

1



Step 12

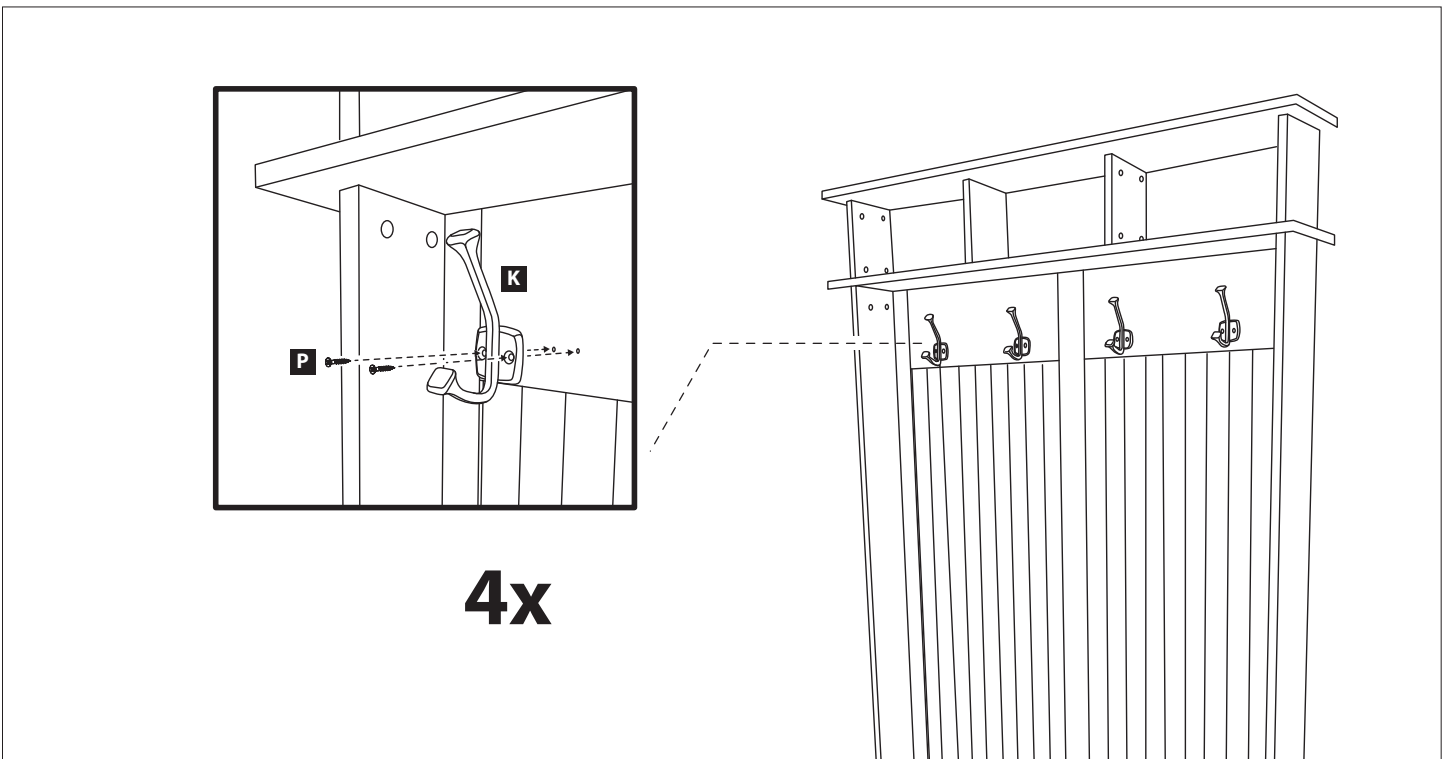

8



Step 13

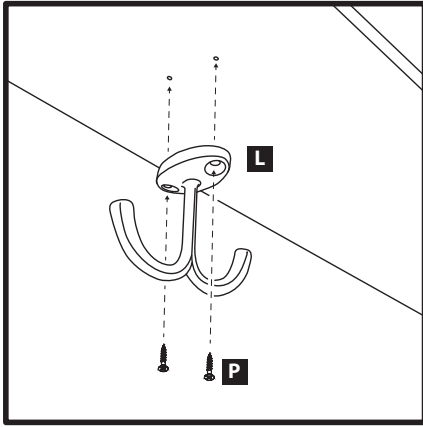

2x

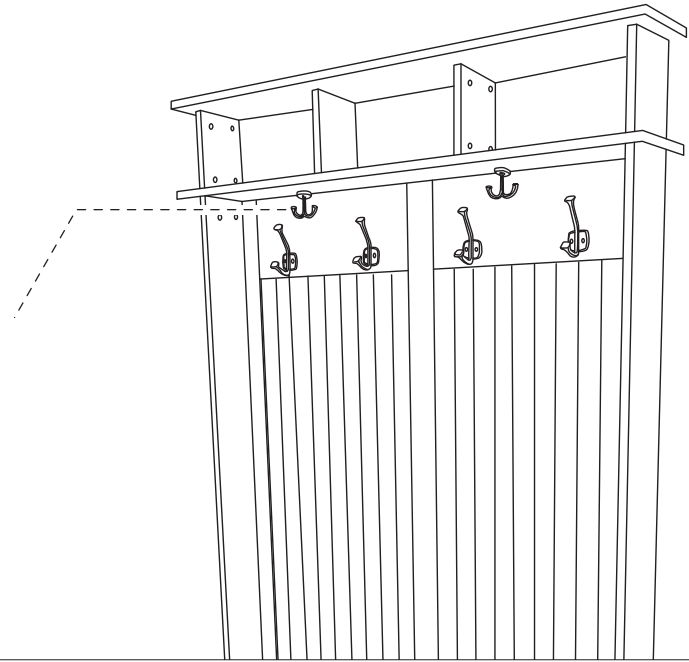

4

