

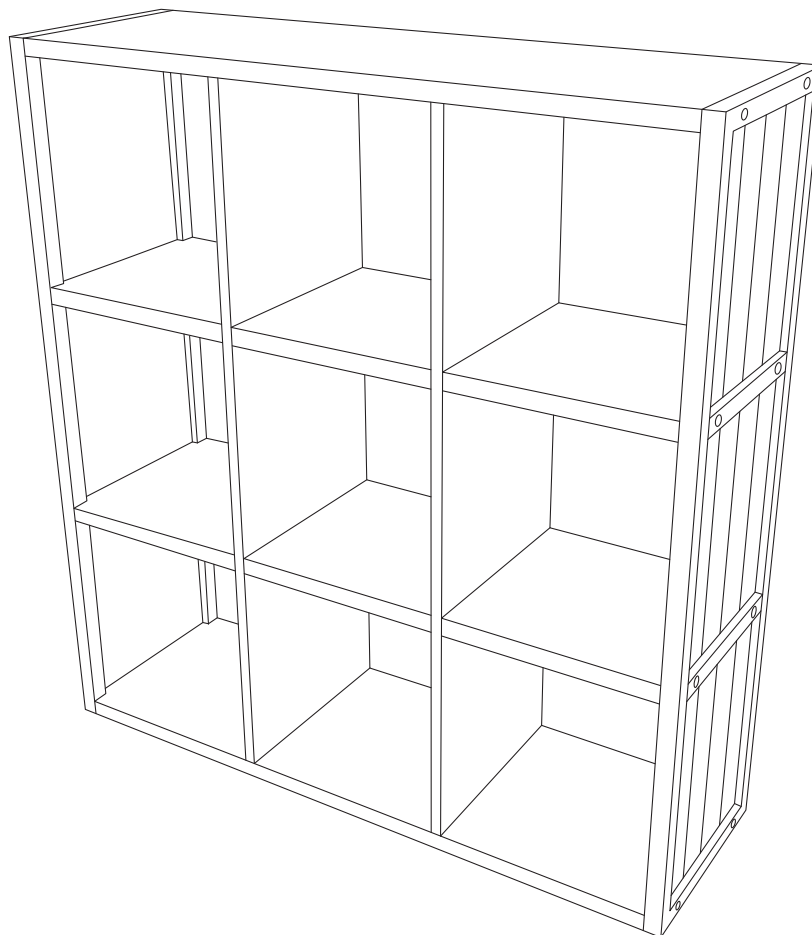

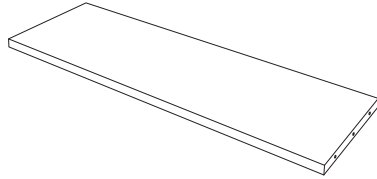

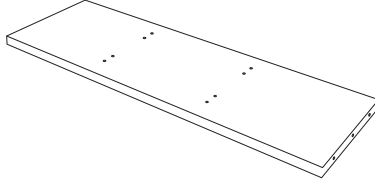

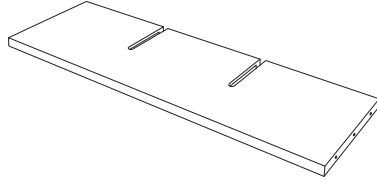
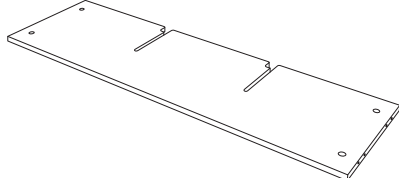
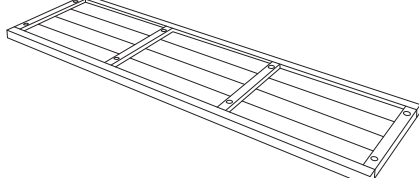

9 Cube Storage System JLH-9C-*

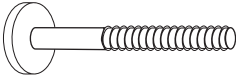

Parts List

		
A 1 Top	B 1 Base	C 2 Horizontal Shelf
		
D 2 Vertical Spacer	E 2 Side	

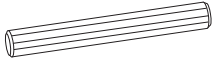
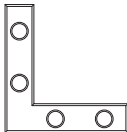
Hardware List

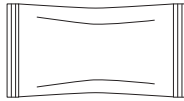
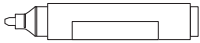
				
F 16 Barrel Bolt	G 16 Barrel Nut	H 8 #CAM Bolt	I 8 CAM Nut	J 16 Bolt Cap
				
K 16 Dowel Pin	L 2 Bracket	M 8 3/4" Screw	N 1 Anti-Tip Hardware	O 1 Touch Up Pen

Required Tools

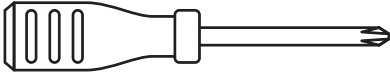
	
P 1 Allen Wrench	Screw Driver

Thank you for your purchase. For any product or installation questions, damages, replacement or missing parts please contact us at:

1.800.480.6975

service@johnlouishome.com

www.johnlouishome.com

Step 1

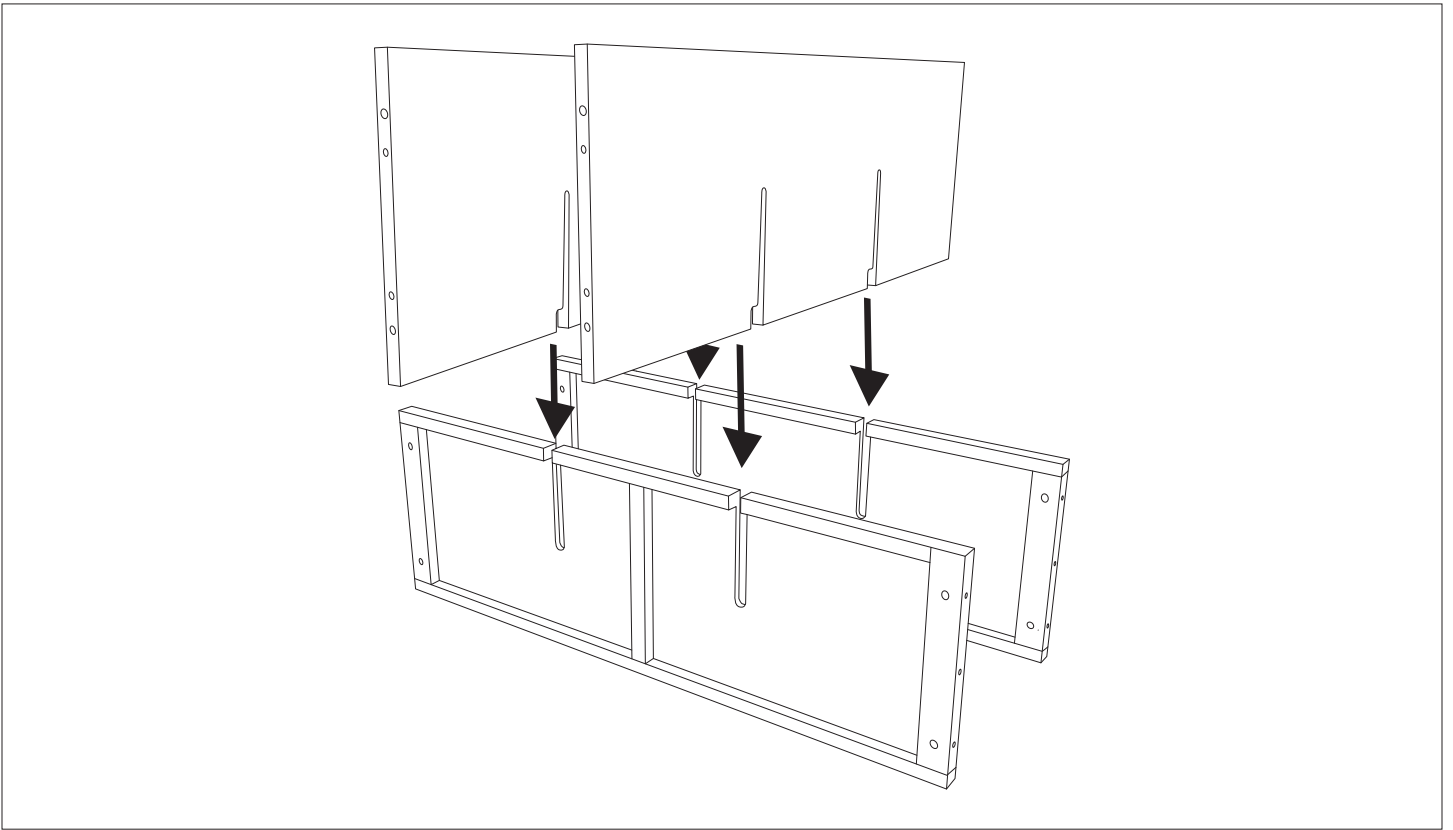

Step 2

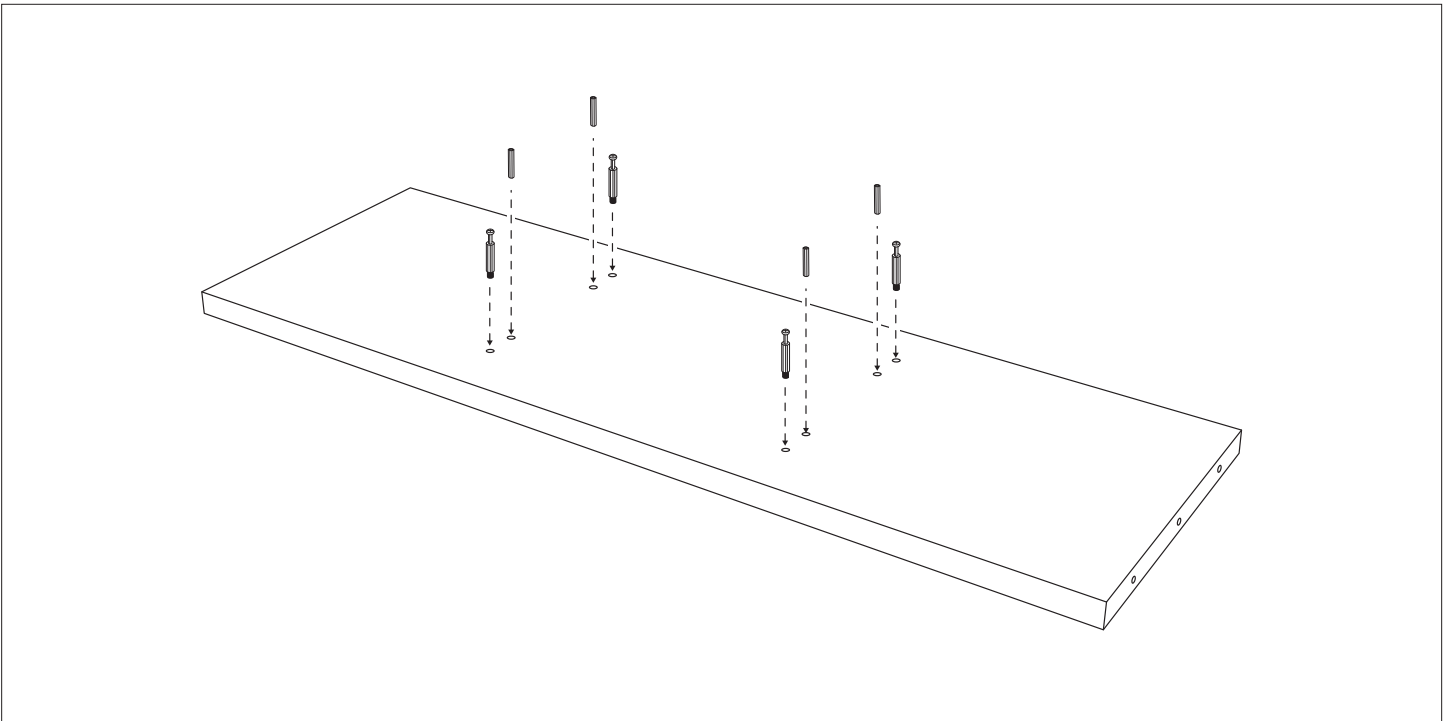

4

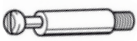

4

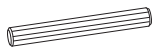

Step 3

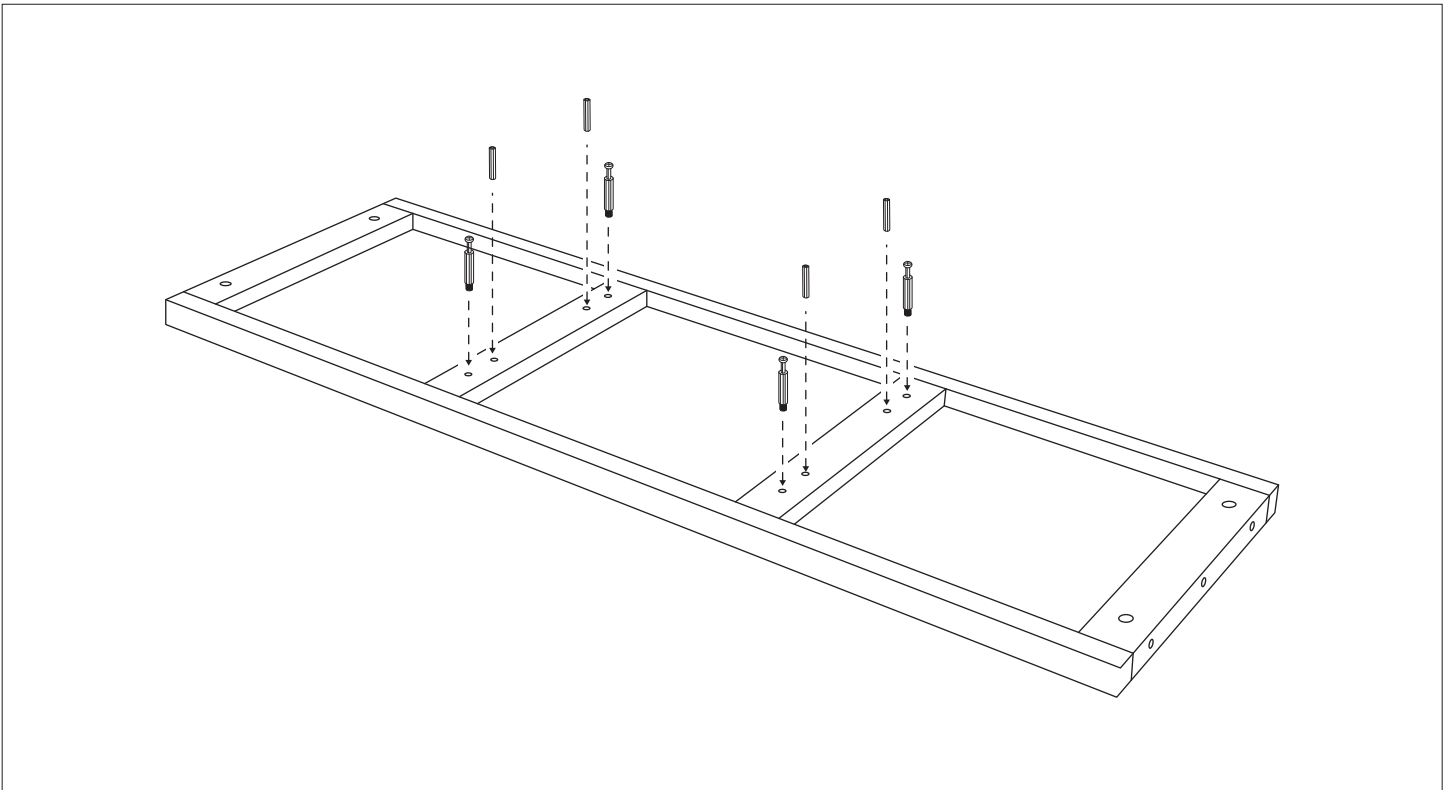

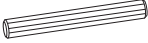
4		4	
----------	--	----------	--

Step 4

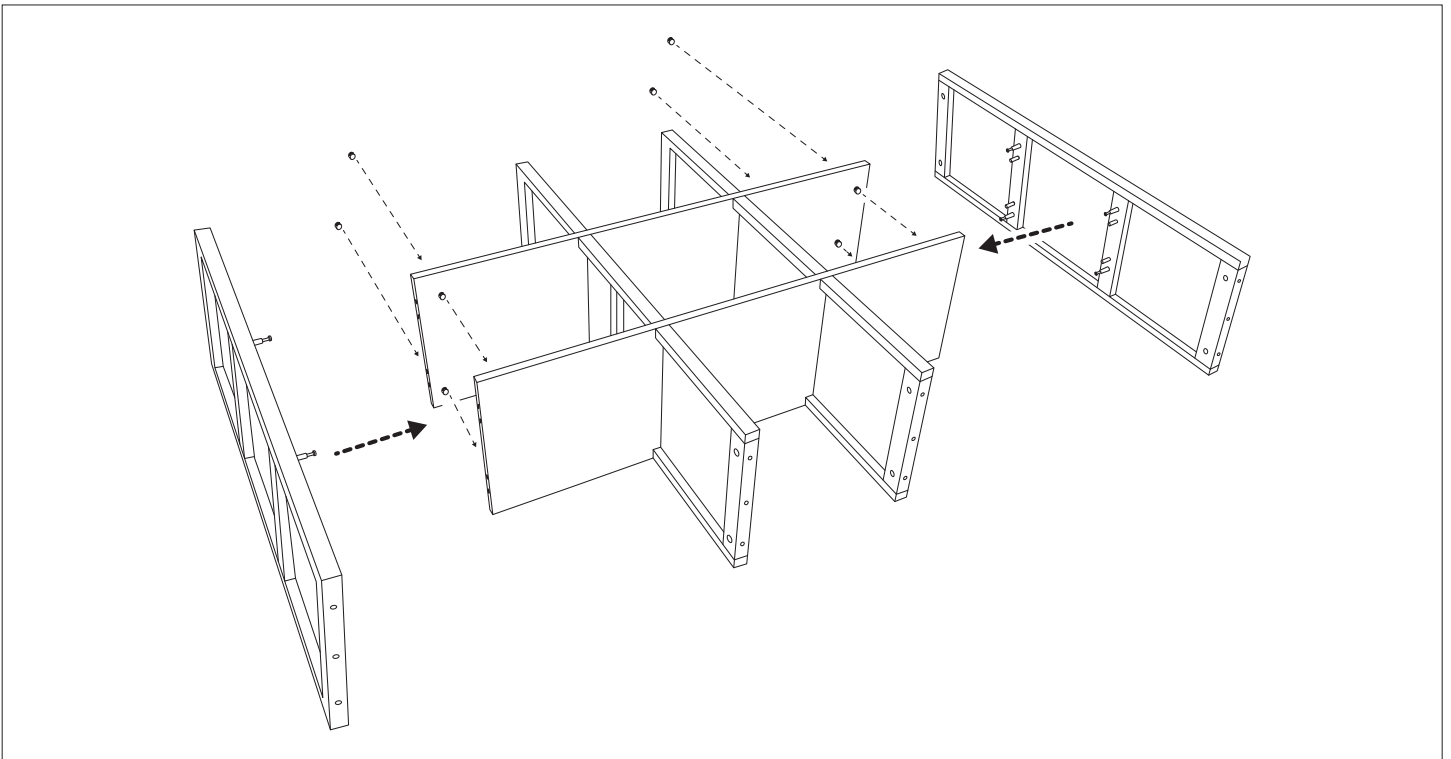

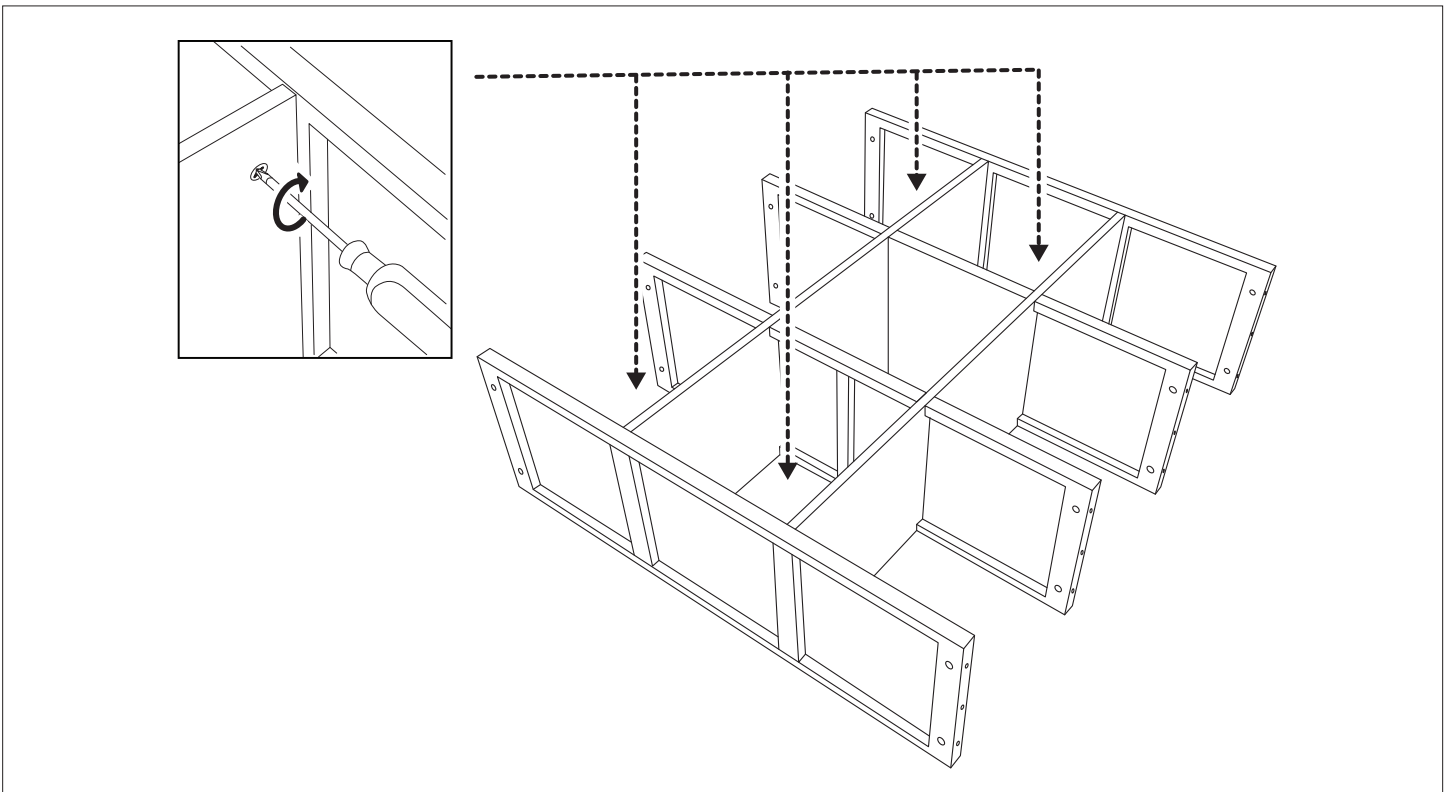

8	
----------	---

Step 5

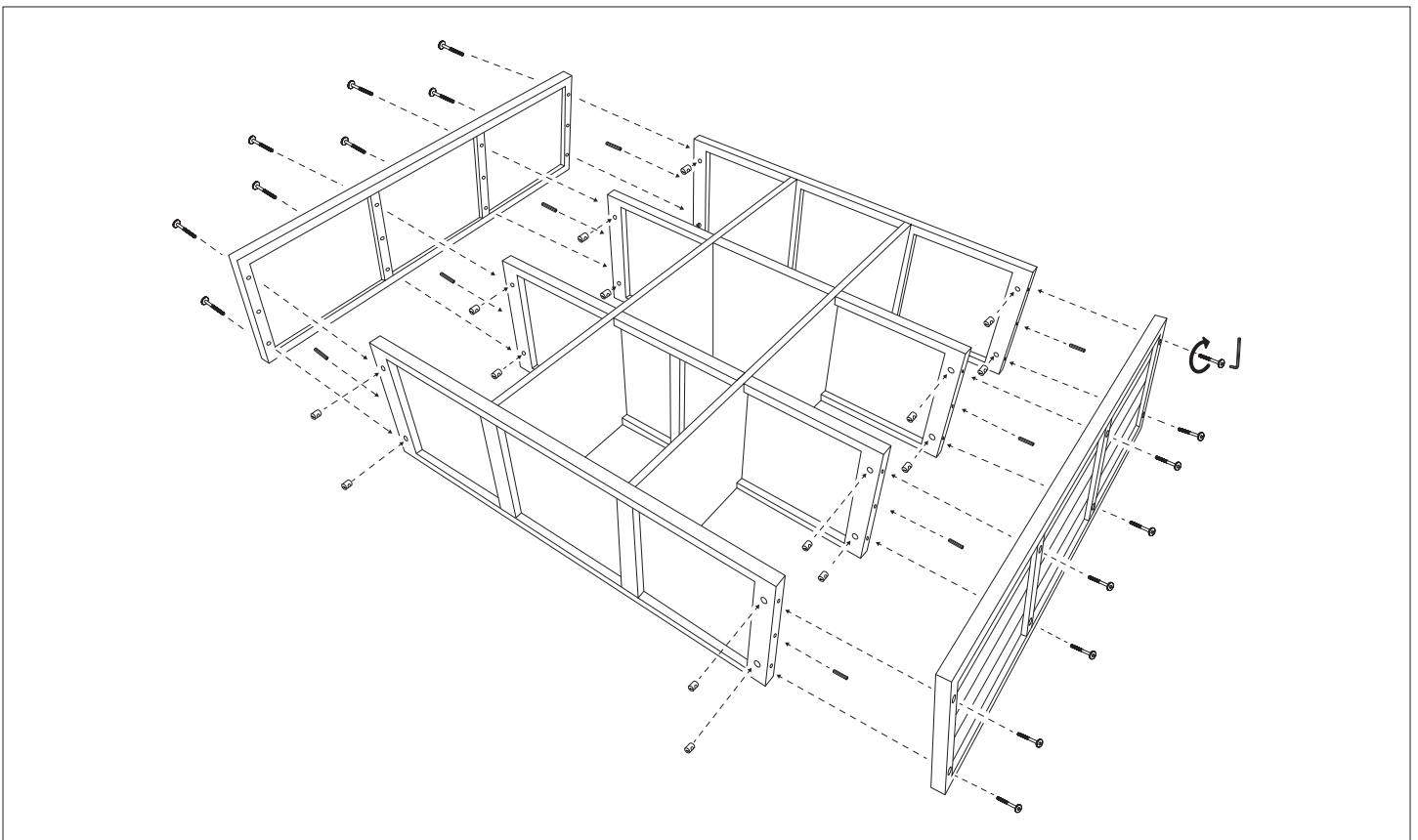

Step 6



16		16		8	
-----------	---	-----------	---	----------	--

Step 7

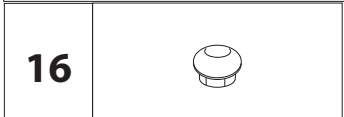
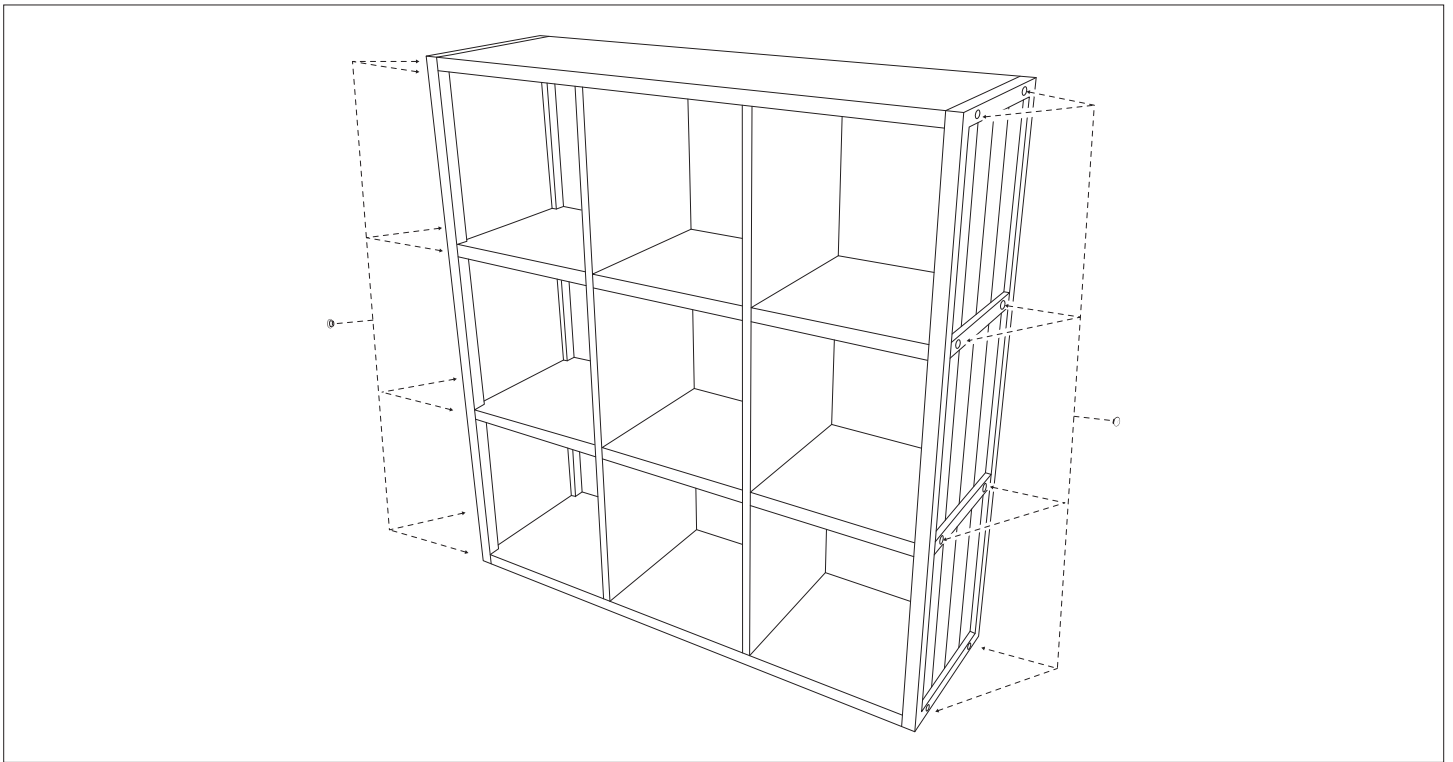

Step 8 (Optional Stacking Fasten)

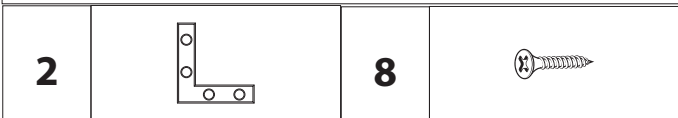
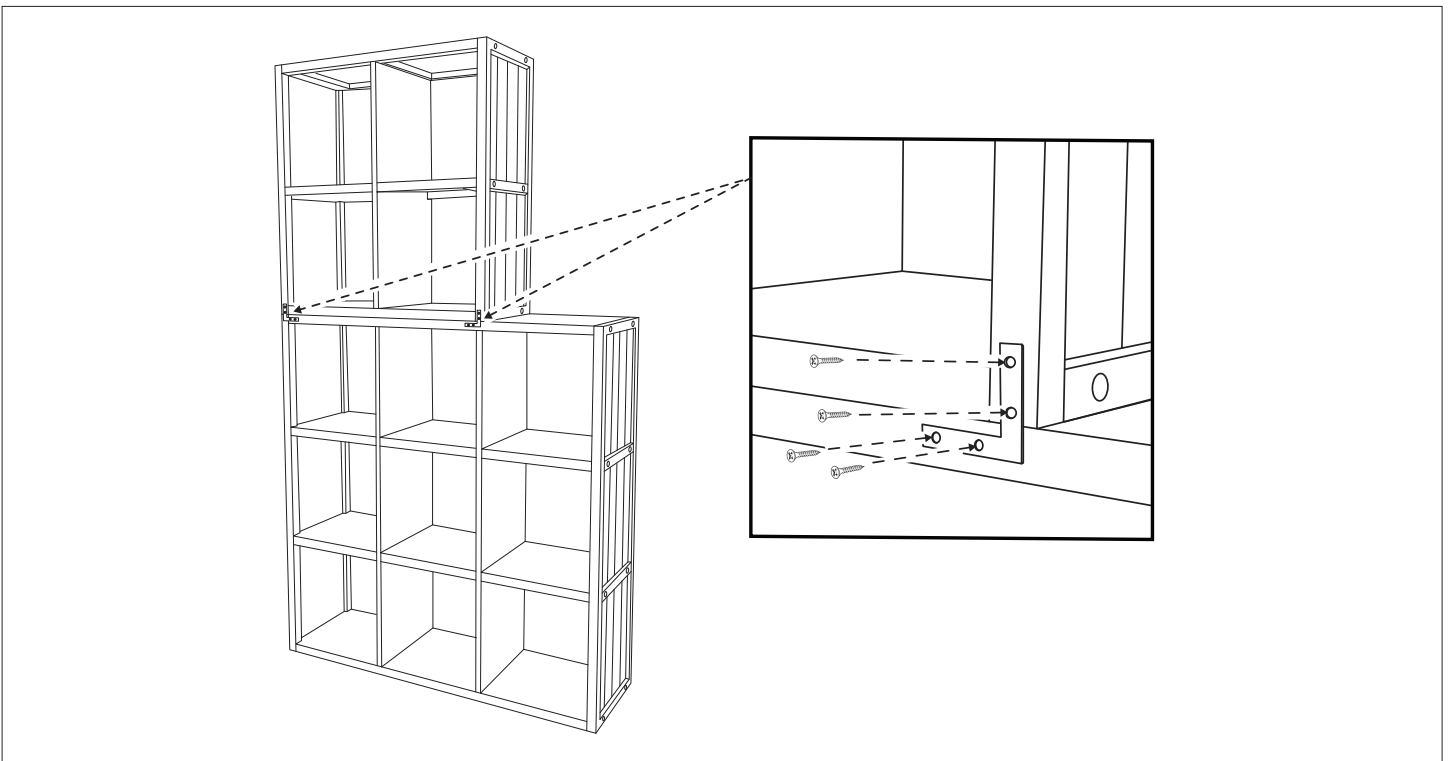

Step 9 (Optional Anti-Tip)

